

COUPLED THERMOGRAVIMETRY/PHOTOMETRY FOR POLYMER IGNITION STUDIES *

BRUCE B. JOHNSON and JEN CHIU

Polymer Products Department, E.I. duPont de Nemours and Company, Experimental Station, Wilmington, DE 19898 (U.S.A.)

(Received 12 December 1980)

ABSTRACT

Evaluation of the ignition properties of a polymeric system is difficult due to the large number of properties that must be measured and correlated. This problem is complicated by the fact that these properties are often measured using different tests under widely varying conditions. We have developed an attachment for a commercial thermogravimetric analyzer that detects ignition and measures smoke generation. Since thermogravimetry provides information concerning the char yield and the decomposition kinetics, four important measures of polymer ignition are thus simultaneously obtained. The use of this apparatus is illustrated on polymeric systems.

INTRODUCTION

Evaluation of the potential combustion hazard of a polymeric system is a complex problem due to the large number of properties that must be measured and correlated. Further complicating the situation is the large number of tests involving different conditions and instrumentation that are used to measure these properties [1]. Table 1 is an incomplete list of combustion related properties and the techniques used to measure them. It is clear that complete characterization of the combustion properties of a polymeric system is a long and arduous task. Since it is often necessary to compare large numbers of potential fire retardant (FR) polymer compositions, a need exists for a relatively quick and simple test that measures many of the combustion related properties of a sample.

We have developed a photometric attachment for a duPont 950 thermogravimetric analyzer (TGA) that enables one to detect ignition and to measure the amount of smoke generated while a TG scan is run. Since the

* Presented at 10th North American Thermal Analysis Society Conference, Boston, 26–29 October 1980.

TABLE 1

Evaluation of FR polymer compositions:

Thermal stability	
Degradation temperature	TGA
Degradation rate	DTG
Ignition temperature	Several
Combustibility	TEA, OI, others
Char yield	TGA
Heat generation	DSC, calorimetry
Evolved gases	TEA
Smoke intensity	Several
Smoke toxicity	Animal tests

thermogravimetric (TG) scan contains information on other combustion properties (e.g. char yield, degradation temperature, and degradation rate), use of the photometric attachment allows a large number of the properties listed in Table 1 to be measured simultaneously. The combined TG/photometry technique measures the response of a sample to a reproducible set of experimental conditions enabling a series of samples to be compared with one another.

The applicability of this combined TG/photometry technique is illustrated on two different FR polymeric systems. First, the technique is applied to the characterization of a series of cellulose samples loaded with different inorganic fire retardants. Second, the technique is used to show the effectiveness of a commercial FR polybutylene terephthalate (PBT) resin.

EXPERIMENTAL

Materials

A series of cellulose samples with different flame retardants was prepared. The cellulose used was cotton linters (No. 6003 from the Polymer Sample Bank provided by the National Bureau of Standards and the Polytechnic Institute of Brooklyn). This cellulose is 99.5% α -cellulose and has a viscosity average molecular weight of 338 580.

Five inorganic flame retardants were selected for comparison. Table 2 lists the flame retardants and the concentrations used. The samples were prepared by soaking the linters for 30 min in aqueous solutions of the flame retardants. The linters were then removed from the solutions and dried for 14 h in a vacuum oven at 50°C. The amount of fire retardant loaded in the linters was taken to be the difference in weight before and after treatment.

In our preparation we aimed at preparing samples that had equal molar ratios of fire retardant to polymer. This ratio or loading number represents the number of molecules of fire retardant per average polymer chain. Table 2 lists the fire retardants used together with the weight percent and the loading number of the samples tested.

TABLE 2

Fire retardant cotton linters

Fire retardant	Wt. %	Loading no. *
None	0.0	0
$\text{Na}_2\text{B}_4\text{O}_7 \cdot 10 \text{H}_2\text{O}$	7.0	127 **
ZnCl_2	4.4	114
H_3PO_4	3.7	133
SbCl_3	7.3	117
$(\text{NH}_4)_2\text{HPO}_4$	4.6	124

* Loading no. = number of fire retardant molecules per average polymer chain.

** Calculated on an anhydrous basis.

Polybutylene terephthalate (PBT) samples used were Valox[®] 310 and Valox[®] 310 SEO (General Electric Co.).

Thermogravimetry

Conventional thermogravimetry was performed using a duPont 950 TGA controlled by a duPont 900 thermal analyzer. Samples were run at $20^\circ\text{C min}^{-1}$ in both air and nitrogen atmospheres (300 ml min^{-1}).

TG/photometry

Figure 1 shows a schematic diagram of the photometric attachment for the duPont 950 TGA module. The TGA furnace was modified by replacing the spherical ball joint with a male 24/40 standard taper joint. The body of

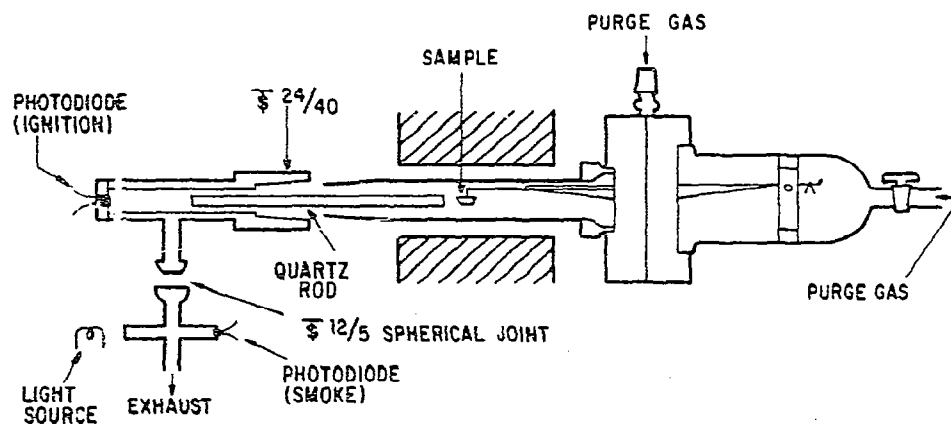

Fig. 1. Schematic diagram of TG/photometry attachment for duPont 950 thermogravimetric analyzer.

the photometric attachment is a stainless steel tube with a female 24/40 standard taper joint allowing the attachment to be quickly removed from the furnace tube and replaced when a sample is to be introduced. At the end of the attachment a threaded piece about 1 in. long made of Teflon[®] TFE resin is used to hold a photodiode (EG & G, PV-100A) in a position such that it "sees" the sample pan. The threaded piece also serves as a thermal insulator for the photodiode.

A fused quartz rod of fiber optic quality ($\sim 3/8$ in. diameter; Heraeus-Amersil, Inc., Sayreville, NJ) is used as a light pipe between the sample and the photodiode. This rod is held by two groups of three nylon screws spaced equally around the diameter of the stainless steel tube. The rod serves to reduce the path length that can be obscured by smoke and to lower the background signal by reducing the aperture of the photodiode. The background signals probably originate from scattered room light and thermal emission by the oven. The scattered room light is reduced further by silvering the inside of the furnace tube any place that the tube is not in the furnace. Thermal emission by the furnace puts an upper temperature limit on the use of our attachment at about 500°C at a heating rate of $100^{\circ}\text{C min}^{-1}$.

As shown in Fig. 1, a stainless steel tee is attached to the exhaust gas path through a 12/5 spherical ball joint. This tee provides a straight-through path for exhaust gases and a perpendicular path to hold a photometer. The photometer measures obscuration by the smoke in the exhaust.

Two types of photometers have been used for smoke detection. The first design consisted of a light bulb and a photodiode mounted on the tee to provide a photometer with an output proportional to the transmittance of the exhaust gas. Later this was replaced by a commercial light source/photodiode combination (Photodyne 99XL densitometer) providing an output proportional to optical density, a quantity directly related to the amount of smoke in the light path.

Photothermal techniques have been used to study ignition [2] and smoke generation [3] behavior in the past, but the combination of both of these techniques with thermogravimetry increases the amount of information available. The second unique aspect of the present apparatus is the use of the quartz rod as a light pipe.

Collins and Wendlandt [2] used a photomultiplier to detect ignition in an apparatus somewhat similar to that reported here. Since the ignition temperature determined in this manner is dependent upon experimental conditions (heating rate, gas flow rate and gas composition), it does not correspond to the auto-ignition temperature measured using other procedures [4,5]. Loehr and Levy [3] coupled a duPont 950 TGA module to a duPont 410 precision photometer to compare the amount of smoke generated by different samples. While the measurement of the ignition temperature and smoke generation by these photothermal methods is not standard, it should be adequate for use in comparison of samples.

Five signals are monitored in an experiment — temperature, weight loss, derivative of the weight loss, light emission by the sample, and obscuration due to smoke. The derivative of the weight loss was obtained by feeding the weight signal into a Cahn time derivative computer.

In the use of this apparatus there are three critical experimental variables — heating rate, purge gas composition, and purge gas flow rate. To compare a series of FR compositions, a variety of conditions are tried on one member of the series, usually the base resin. The optimum conditions for screening the series are those in which the base resin degrades readily and, if possible, ignites. These conditions are then applied to all members of the series. For systems based on extremely stable polymers a purge gas enriched in oxygen (e.g. 30% oxygen, 70% nitrogen) may have to be used. Flow rates are measured with a Matheson mass flow meter and reproduced to within 1%.

Figure 2 shows an example of the data obtained for a typical filter paper with the TG/photometry apparatus. These data were taken with the early version of the smoke intensity photometer which had an output proportional to transmittance.

Samples are run in triplicate. Reported values are averages of the properties measured for the three runs. The six properties measured appear to give a reasonably definitive characterization of the sample behavior.

(1) The degradation temperature (T_1^{\max}) is the temperature at which the maximum rate of weight loss occurs.

(2) The degradation rate (R_d) is the normalized maximum rate of weight loss (in wt. % sec⁻¹)

$$R_d = \frac{R_{\max}}{w} \times 100$$

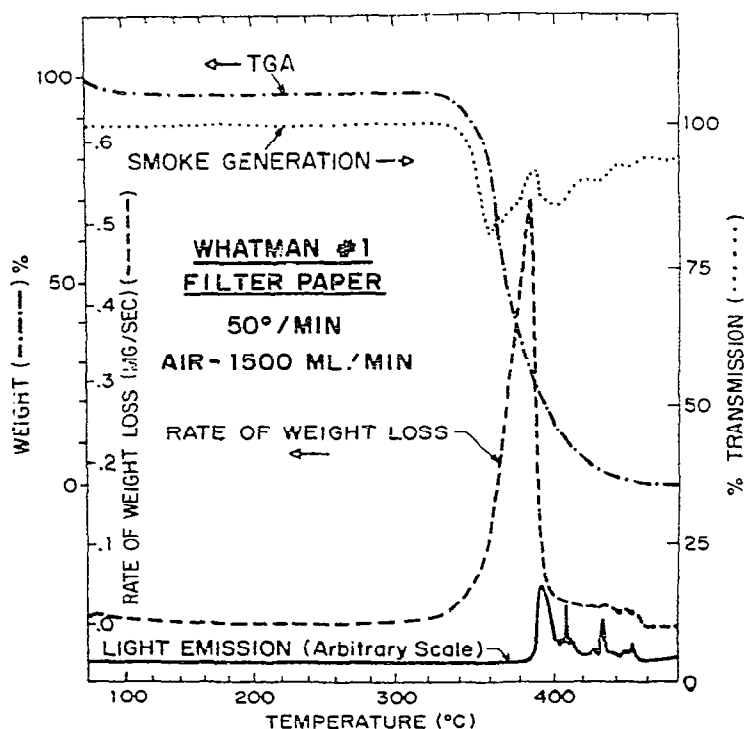

Fig. 2. TG/photometry of Whatman No. 1 filter paper.

where R_{\max} is the maximum rate observed (mg sec^{-1}) and w is the sample weight (mg).

(3) The half-width of degradation ($t_{1/2}^d$) is the width of the rate of weight loss peak at half-height.

(4) The ignition temperature (T_{ig}) is the temperature at which light emission is first observed.

(5) The smoke intensity (SI) is proportional to the area of the smoke peak. We use a semiquantitative measure of this area — the product of the normalized maximum optical density (OD_R) and the width at half-height of the smoke peak ($t_{1/2}^s$)

$$\text{SI} = \text{OD}_R \times t_{1/2}^s$$

where

$$\text{OD}_R = \frac{\text{OD}_{\max}}{w} \times 100$$

(6) The "char" yield is the amount of sample left at the end of the first weight loss.

Table 3 summarizes results for cotton linters obtained from several runs made over a period of more than 1 month. With the exception of one run (marked with a question mark), the reproducibility of the six properties measured appears extremely good. The observed ranges of values for T_1^{\max} and T_{ig} are about 20° , while the degradation rate (R_d) and half-time ($t_{1/2}^d$) appear to have about $\pm 20\%$ ranges. The relative smoke intensity (SI) is not as exact a measurement, with an apparent range of $\pm 50\%$.

TABLE 3

TG/photometry: reproducibility

Atmosphere	Flow rate (l min^{-1})	Date	T_1^{\max} ($^\circ\text{C}$)	R_d ($\text{wt.}\%$ sec^{-1})	$t_{1/2}^d$ (sec)	SI	T_{ig} ($^\circ\text{C}$)
30 : 70/ O_2 : N_2	0.75	21 Aug.	366	4.3	16	24	362
		15 Sept.	346	3.6	21	22	341
		16 Sept.	343	3.9	20	28	339
		19 Sept.	339	3.4	19	29	335
		22 Sept.	295	3.3	22	21	292 ?
		3 Oct.	352	3.6	18	31	350
		6 Oct.	351	4.7	16	25	350
		7 Oct.	350	3.8	20	41	348
Air	0.75	26 Aug.	370	2.8	27	20	371
		2 Oct.	365	2.7	27	30	365
		3 Oct.	361	2.6	30	30	360
		6 Oct.	362	2.8	26	49	362
		8 Oct.	357	3.1	26	36	357

Heating rate = $50^\circ\text{C min}^{-1}$.

RESULTS AND DISCUSSION

Thermogravimetry — cotton linters

Conventional TG studies of FR polymer compositions involved comparing the TG scans of the base resin with those of the FR compositions. When the scans were obtained using a nitrogen atmosphere two important properties were measured — the char yield and the degradation temperature. Figure 3 compares the TG scans of neat cotton linters with those of the linters loaded with ZnCl_2 in atmospheres of nitrogen and air.

In a nitrogen atmosphere the effect of the ZnCl_2 on the degradation of the linter is to increase the char yield two-fold and to decrease the degradation temperature. Table 4 shows that all the FR linters had a similar increase in char yield accompanied by a decrease in degradation temperature. The degradation temperature (T_d) is taken to be the temperature at which the first degradation step ends. The T_d of the H_3PO_4 /linter is significantly lower than that of the other FR linter, while that of the neat linter is significantly higher.

In an air atmosphere, the behavior of the FR linters changes considerably. All the samples show a two-step degradation. The amount of residue at the end of the first step is referred to as the “char” yield due to its analogous

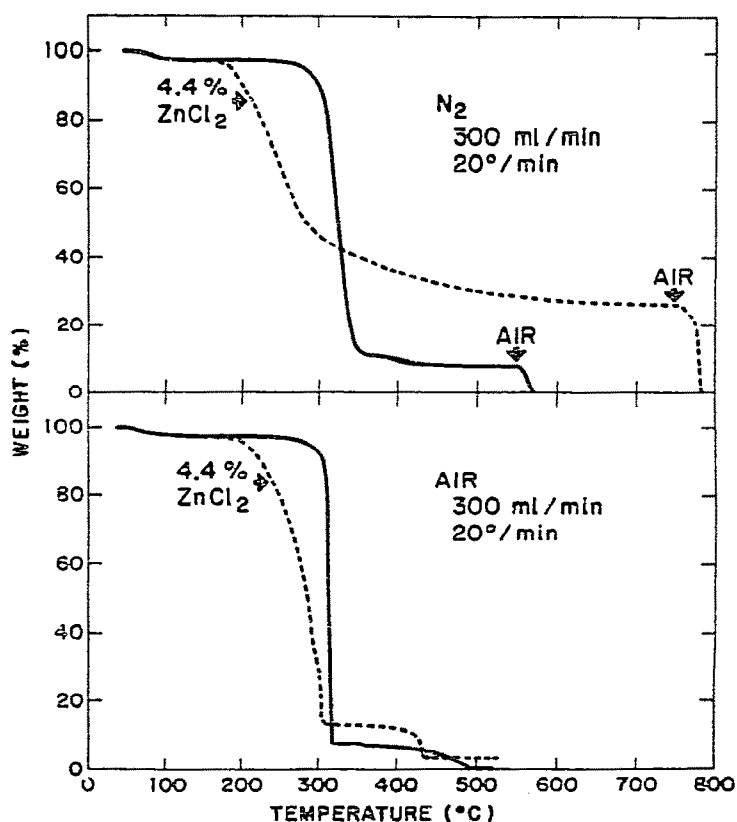

Fig. 3. TG of cotton linters.

TABLE 4
TG of FR cotton linters

Fire retardant	N ₂		Air	
	T _d (°C)	Char (wt.%)	T _d (°C)	"Char" (wt.%)
None	345	12	320	8
Na ₂ B ₄ O ₇ · 10 H ₂ O	320	53	330	18
ZnCl ₂	285	48	304	13
H ₃ PO ₄	250	54	295	37
SbCl ₃	295	50	320	12
(NH ₄) ₂ HPO ₄	280	50	280	48

relationship with the conventionally defined char yield. Only the linters loaded with H₃PO₄ and (NH₄)₂HPO₄ show "char" yields close to the char yields. The other FR linters show "char" yields only a small amount above that of the neat linter.

TG/photometry — cotton linters

The conventional TG study of the FR cotton linters shows clearly that the fire retardants have an effect, but give inadequate information on the relative effectiveness of the various FR compositions. The results suggest that H₃PO₄ and (NH₄)₂HPO₄ have different effects on the flammability of the cotton linters. Application of the TG/photometry technique gives a much more definitive picture of the relative merit of the FR compositions.

Table 5 summarizes the TG/photometry results for the FR cotton linters. Several features are evident.

(1) Although use of any flame retardant reduces T_1^{\max} , the linters loaded

TABLE 5
TG/photometry of FR cotton linters

Fire retardant	T ₁ ^{max} (°C)	R _d (wt. % sec ⁻¹)	t _{1/2} ^d (sec)	SI	T _{ig} (°C)	"Char" (wt.%)	Rank (subjective)
None	365	2.7	27	30	365	<1	5
Na ₂ B ₄ O ₇ · 10 H ₂ O	312	4.5	9	3	311	11	4 ?
ZnCl ₂	305	2.6	8	5	301	9	3
SbCl ₃	307	2.8	11	4	304	8	3
H ₃ PO ₄	290	1.9	23	0	286 *	33	2
(NH ₄) ₂ HPO ₄	275	1.1	48	0	nd **	37	1

Heating rate = 50° C min⁻¹; atmosphere of air at a flow rate of 750 ml min⁻¹.

* Weak emission.

** nd = none detected.

with H_3PO_4 and $(\text{NH}_4)_2\text{HPO}_4$ have significantly lower T_1^{max} values.

(2) The two measures of degradation rate (R_d and $t_{1/2}^d$) show that the linters loaded with H_3PO_4 and $(\text{NH}_4)_2\text{HPO}_4$ have the lowest degradation rates. The linters loaded with SbCl_3 and ZnCl_2 show rates equal to that of the neat linter, but the half-widths are less. Since the samples loaded with SbCl_3 and ZnCl_2 degrade at rates near their peak rates for shorter times than the neat linter, the overall rates are lower than those of the neat linter. The linter loaded with $\text{Na}_2\text{B}_4\text{O}_7 \cdot 10 \text{H}_2\text{O}$ has a half-width much lower than that of the neat linter, but a maximum rate about 1.5 times as large.

(3) All of the FR linters show much less smoke than the neat linter, but those loaded with $(\text{NH}_4)_2\text{HPO}_4$ and H_3PO_4 have a SI of 0. A SI of 1 would be detectable with the TG/photometry apparatus.

(4) All linters except the one loaded with $(\text{NH}_4)_2\text{HPO}_4$ ignited at temperatures close to the respective degradation temperatures. It is clear that the ignition temperature is not as important as the observation of whether or not the sample ignites. Ignition was not detected for one sample [$(\text{NH}_4)_2\text{HPO}_4$] and one sample (H_3PO_4) exhibited only a weak emission.

(5) The "char" yield data parallel those found in the conventional TG study. Two samples [$(\text{NH}_4)_2\text{HPO}_4$ and H_3PO_4] showed large "char" yields (30–40%) when compared to the other samples.

Using the measured properties to obtain an overall rating of the FR composition is a subjective task. In different applications of a resin, different properties of the FR composition might be more important. However, in evaluating the data obtained on FR cotton linters, a relatively straightforward ranking can be made.

In every property two of the FR compositions appear to be better than the others. These are the samples loaded with $(\text{NH}_4)_2\text{HPO}_4$ and H_3PO_4 . Between these two $(\text{NH}_4)_2\text{HPO}_4$ seems to be a slightly better flame retardant. The linter loaded with $(\text{NH}_4)_2\text{HPO}_4$ has a lower degradation temperature (275 vs. 290°C), a lower degradation rate (1.1 vs. 1.9 wt. % sec^{-1}), and a longer half-width (48 vs. 23 sec) than the linter loaded with H_3PO_4 . In addition, ignition was not detected for the linter loaded with $(\text{NH}_4)_2\text{HPO}_4$, while a weak emission was detected for the linter loaded with the H_3PO_4 .

Rating the other three FR linters is more difficult. The only significant difference is in degradation rate. Two of the three (ZnCl_2 and SbCl_3) have rates similar to that of the neat linter (R_d 2.7 wt. % sec^{-1}), while one ($\text{Na}_2\text{B}_4\text{O}_7 \cdot 10 \text{H}_2\text{O}$) has a rate ($R_d = 4.5$ wt. % sec^{-1}) larger than the neat linter. Based on this difference, the linters loaded with ZnCl_2 and SbCl_3 are both rated third, and the linter loaded with $\text{Na}_2\text{B}_4\text{O}_7 \cdot 10 \text{H}_2\text{O}$ is rated fourth. A question remains as to why the degradation rate for this sample is higher than that of the neat linter.

TG/photometry — polybutylene terephthalate

The results of the study of FR cotton linters show that useful information can be obtained from the combined TG/photometry technique in studying FR polymer compositions. To test the applicability of the technique to other types of polymers we have used it to compare a commercially available

TABLE 6
TG/photometry of PBT

Sample	T_1^{max} (°C)	R_d (wt.% sec)	$t_{1/2}^d$ (sec)	T_2^{max} (°C)	T_{ig} (°C)	SI	"Char" (wt.%)
Valox [®] 310	443	5.5	16	489	482	≥160	6
Valox [®] 310 SEO	405	3.7	36	496	484	56	29

Heating rate = 100°C min⁻¹; atmosphere of 30 : 70 O₂ : N₂ at a flow rate of 2500 ml min⁻¹.

polybutylene terephthalate (PBT) resin (Valox[®] 310) with its FR version (Valox[®] 310 SEO) (Table 6). All properties measured indicate that Valox[®] 310 SEO is an effective FR polymer composition. In the FR version the degradation temperature and rate are lowered, the char yield increases, and the relative smoke intensity decreases. Neither sample ignites during the first step of degradation.

For this study a high flow rate of an oxygen enriched atmosphere was necessary to bring out the differences. At the heating rates obtainable on the duPont 950 TGA, the use of an enriched atmosphere is often necessary to ignite samples.

SUMMARY

In this paper we have reported the development of a photometric attachment for the duPont 950 TGA designed for the study of the ignition of polymers. Application of TG/photometry to two FR polymeric systems shows the usefulness of the technique in studying the effectiveness of a flame retardant polymer composition.

TG/photometry measures the response of a sample to a reproducible environment. Different FR polymer compositions subjected to the same environment respond differently, and the observed differences appear to be related to differences in the effectiveness of the FR system. This suggests that TG/photometry will be useful as a test for screening FR polymer compositions.

While a large number of combustion related properties are measured in the TG/photometric technique discussed above, by no means is a complete characterization of the combustibility of a sample made. In addition, the various properties measured are not inherent properties of the sample, but depend markedly on the experimental conditions. In spite of these cautionary notes, we believe the TG/photometric technique is useful because using TG/photometry a large number of samples can be compared relatively quickly and simply.

REFERENCES

- 1 Fire Safety Aspects of Polymeric Material, Vol. 5, National Materials Advisor Board, NRC, 1979.
- 2 L.W. Collins and W.W. Wendlandt, *Thermochim. Acta*, 7 (1973) 201.
- 3 A.A. Loehr and P.F. Levy, *Am. Lab.*, 4 (1) (1972) 11.
- 4 B. Miller and J.R. Martin, in M. Lewin, S.A. Atlas and E.M. Pearce (Eds.), *Flame-Retardant Polymeric Materials*, Vol. 2, Plenum Press, New York, 1978, p. 63.
- 5 V.P. Setchkin, *J. Res. Natl. Bur. Stand.*, 43 (1949) 591.